

Technical data sheet

Product features



Electric range with hot air oven

Model	SAP Code	00014791
--------------	-----------------	----------



- Device type: Electric unit
- Power consumption of the zone 1 [kW]: 2,5
- Power consumption of the zone 2 [kW]: 2,5
- Power consumption of the zone 3 [kW]: 2,5
- Power consumption of the zone 4 [kW]: 2,5
- Type of internal part of the appliance 1 (eg oven): Electric
- Type of internal part of the appliance 2 (eg oven): Hot air
- Protection of controls: IP24
- Material: AISI 304 top plate and cladding

SAP Code	00014791	Number of zones	4
Net Width [mm]	800	Power consumption of the zone 1 [kW]	2,5
Net Depth [mm]	730	Power consumption of the zone 2 [kW]	2,5
Net Height [mm]	900	Power consumption of the zone 3 [kW]	2,5
Net Weight [kg]	122.90	Power consumption of the zone 4 [kW]	2,5
Power electric [kW]	13.130	Type of internal part of the appliance 1 (eg oven)	Electric
Loading	400 V / 3N - 50 Hz	Type of internal part of the appliance 2 (eg oven)	Hot air

Technical data sheet

Technical drawing



Electric range with hot air oven

Model

SAP Code

00014791

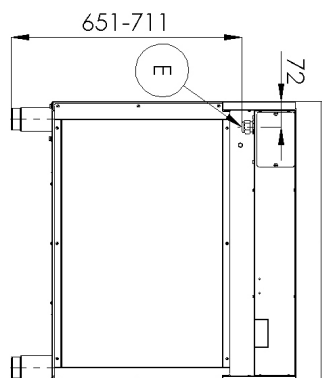
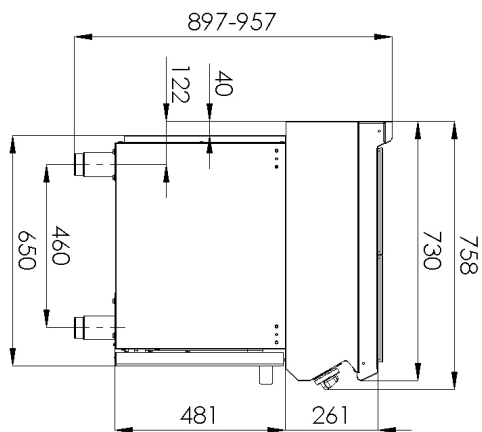
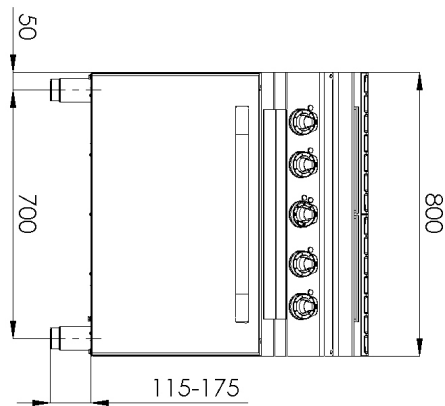

Technical data sheet

Product benefits



Electric range with hot air oven

Model	SAP Code	00014791
-------	----------	----------

1

Square

heat

Effective cooking on a large neighborhood

- saving time when preparing meals
- Easy to operate thanks to a large area

2

Internal thermostatic protection of the hob

a longer life of the hob

3

Degree of protection of controls IPX4

maintenance -free

water resistance

long life

- Savings on service interventions
- easy cleaning of the device

4

Nationheres

long life

Cut -made steel of 10 mm thick boards

- Savings on service interventions
- higher corrosion resistance

5

Hygienic embossments of the top plate

absence of sharp corners and edges (potential places where dirt could adhere)

smooth transitions

- Simple fast cleaning

6

A hot air oven with four positions of grate

hot -air baking

high capacity and variability

nationheres

- Suitable for meat, fish, baked pasta, white meat, sweet pastry
- long life
- simple cleaning

Technical data sheet

Technical parameters



Electric range with hot air oven

Model

SAP Code

00014791

1. SAP Code:

00014791

2. Net Width [mm]:

800

3. Net Depth [mm]:

730

4. Net Height [mm]:

900

5. Net Weight [kg]:

122.90

6. Gross Width [mm]:

840

7. Gross depth [mm]:

800

8. Gross Height [mm]:

1080

9. Gross Weight [kg]:

132.00

10. Device type:

Electric unit

11. Construction type of device:

Stationary

12. Power electric [kW]:

13.130

13. Loading:

400 V / 3N - 50 Hz

14. Protection of controls:

IP24

15. Exterior color of the device:

Stainless steel

16. Material:

AISI 304 top plate and cladding

17. Indicators:

operation

18. Worktop type:

Molded - comfortable cleaning maintenance

19. Worktop material:

AISI 304

20. Worktop Thickness [mm]:

1.50

21. Number of zones:

4

22. Power consumption of the zone 1 [kW]:

2,5

23. Power consumption of the zone 2 [kW]:

2,5

24. Power consumption of the zone 3 [kW]:

2,5

25. Power consumption of the zone 4 [kW]:

2,5

26. Maximum device temperature [°C]:

400

27. Minimum device temperature [°C]:

50

28. Number of power control stages:

6

Technical data sheet

Technical parameters



Electric range with hot air oven

Model

SAP Code

00014791

29. Service accessibility:

Trough the frontal panel

30. Adjustable feet:

Yes

31. Number of burners/hot plates:

4

32. Type of electric cooking zones:

Squared

33. Oven Type:

electric hot air

34. Oven power electric [kW]:

3.13

35. Oven size:

GN 1/1

36. Type of internal part of the appliance 1 (eg oven):

Electric

37. Type of internal part of the appliance 2 (eg oven):

Hot air

38. Gasket:

Yes

39. Maximum temperature of the inner chamber [°C]:

300

40. Minimum temperature of the inner chamber [°C]:

50